

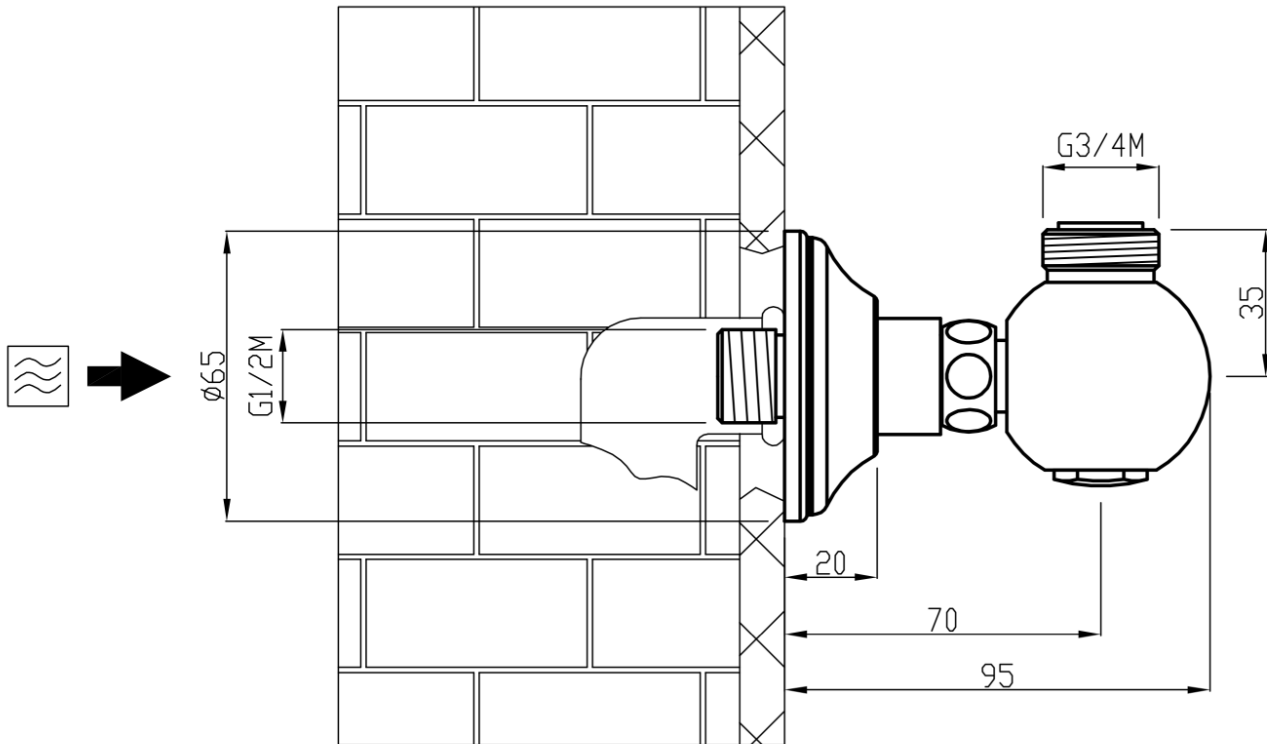

CALFLEX®

Wall mounted connection
Art: 5-20870-SFE

Specifications



- Handmade in Italy
- Suitable for even and uneven pressure

Installation Instructions Model : 5-20870-SFE

1 Preparation

- Flush out the pipework to remove any foreign matter.
- Fix the water wall plate elbow 15mmx1/2" Female BSP, at the required position.
- Fitting cut out hole sizes : Maximum **45mm** diameter.

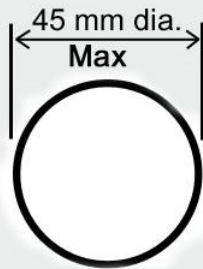

Not supplied:- Water Wall Plate Elbow 15mm x 1/2" Female BSP

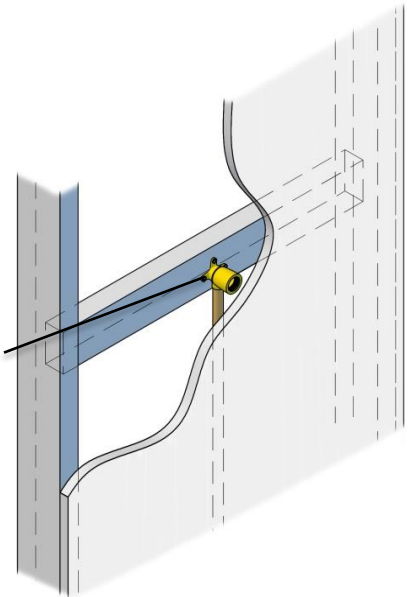

- ## 2
- Install the connector pipe **1**, into the wall elbow connector. Ensure that the pipe is adequately sealed using PTFE tape or appropriate sealing material to ensure a water tight connection.

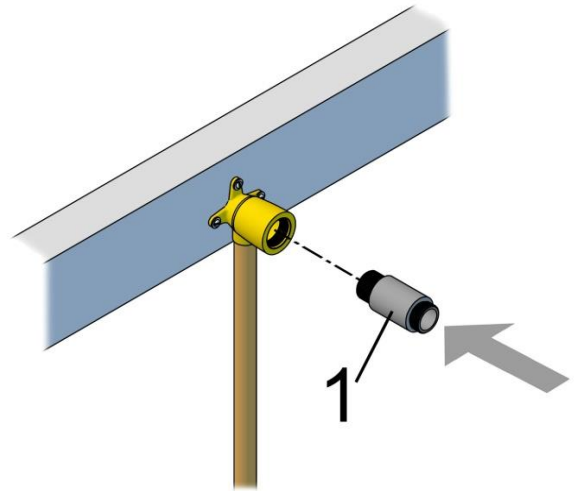

- ## 3
- Slide the cover plate **2**, over the connector pipe, until it is located against the finished/ tiled wall surface.

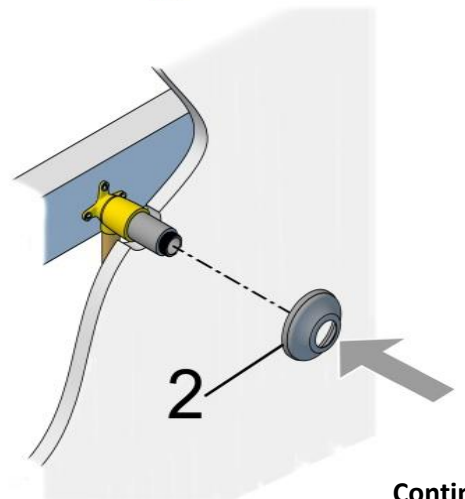

Continue.....

Installation Instructions Model : 5-20870-SFE

- 4**
- Connect the main wall connector body **4**, to the connector pipe.
 - Ensure that the fibre washer **3**, is correctly positioned between the connector pipe thread section and the main body connector nut.
- 5**
- Before final tightening, ensure the main body is correctly orientated.
 - Once in the correct position, tighten the main body connector nut **5**.

NOTE: Be careful not to over tighten, as this could damage the fitting.

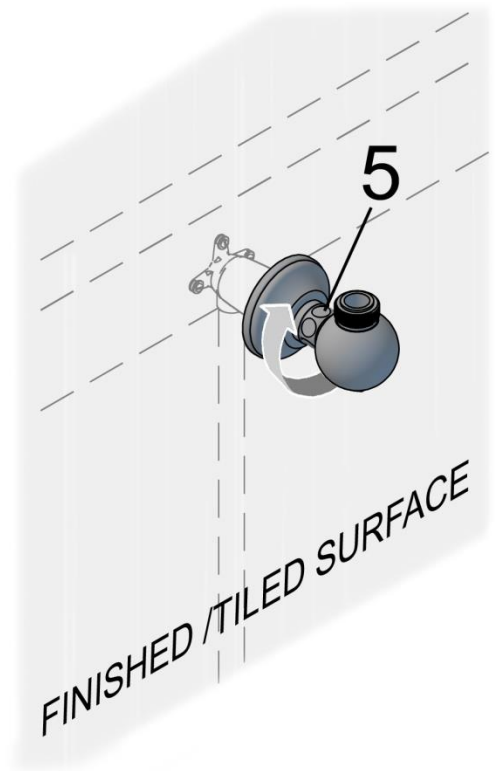
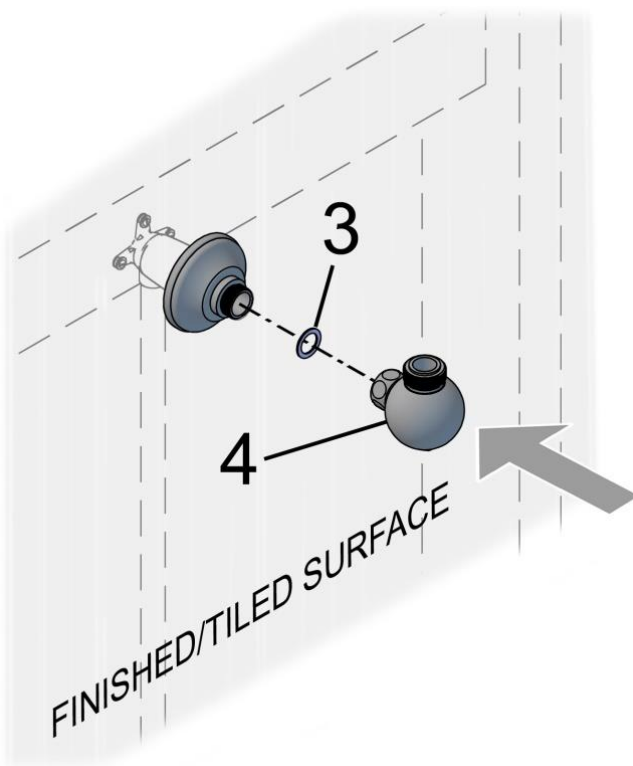

Before use

- Turn on the Hot and Cold water supplies to the appropriate tapware.
- Maximum temperature for Hot water supply to the tapware is 62 °C.
- Minimum recommended pressure is 100 kPa — Maximum recommended pressure is 500 kPa.
- Check the installation carefully for leaks.
- If further building work is to be carried out in the vicinity of the tapware, it should be covered to prevent paint, adhesive, etc. from damaging the surface.

Care and Maintenance Instructions Model : 5-20870-SFE

Care of external finishes

All products are have authentic finishes that have not been coated with any product. After each use, pat the fixture down to remove any excess water. This will prevent any water spotting or mineral build-up. Use only soft liquid soap and water to clean the surface. Use a soft brush to clean any gaps. Avoid any products that have ammonia or alcohol like Windex, Jif or Ajax. These products can damage the finish leaving black or white spots. Never use on abrasive products on tap ware or this will devoid the warranty.

Live Finishes DO NOT carry a warranty as they are living finishes and will change over time.

Raw Brass, Brush Brass (To make the brass lighter again, rub the brass tap with lemon juice, this will lighten the dark colouring).

Shiny Brass, Polished Nickel has an ageing process and will tarnish over time.

Tuscan Brass is a living finish and also carries NO warranty. It will lighten with use. To extend the life of the finish, apply Bruno's Wax by patting it on, letting it dry and patting it off. Never rub or buff this finish.

WARNING: The use of cleaning products not recommended might irreparably harm the surfaces of the tap, which in such cases are not covered by our warranty.